



# Fanden Pty Ltd

## DipFiller for Fuel Miser

### Model Identification Photographs

Working Concept Model	Pre Production Prototype	Production Model
		

urgently developed in 6 days from order, 3 units were produced and fitted to 81 class locomotives	another rapid development, 3 units all fitted to 90 class locomotives	units fitted to 81, 82 & 90 class locomotives
not numbered	DF0106001 to DF0106003	DF0108004 to DF 0XXXYYY
<p><b>NB: not for permanent use</b> these units have been in service for much longer than the requested 2 months, their 6 month design life is long exceeded. They will eventually fail in service without warning. Do not connect to remote BITE monitoring equipment.</p> <p><b>Can be identified by:</b> 3 LEDs, 2 Fuses and bright yellow "not for permanent use" label on front panel. NOTE, these were built using parts immediately available and do not have full functionality of later models</p>	<p><b>Suitable for long term use</b> with possible exception of front panel label (a low temperature label was used at FreightCorp's request to allow early delivery).</p> <p>Major improvement on working concept model. Includes local &amp; remote BITE. Physically &amp; electrically able to be used in place of both other models.</p> <p><b>Can be identified by:</b> recessed LEDs, no external fuses, white label and blue insulator in front mounted panel connector.</p>	<p><b>Suitable for long term use</b></p> <p>snap on voltage raised to 15.5 V with tightly controlled off delay</p> <p>includes local &amp; remote BITE</p> <p>physically &amp; electrically able to be used in place of both previous models.</p> <p><b>Can be identified by:</b> black insulator in a rear mounted panel connector, high temperature label (200°C tested)</p>

The current issue of this document may be found at [www.fanden.com.au/dipfiller/manual.pdf](http://www.fanden.com.au/dipfiller/manual.pdf)



ABN 23 093 030 356

PO Box 498 Baulkham Hills NSW 1755

Phone: (02) 9639 6238 Fax (02) 9639 7462

Internet: [www.fanden.com.au](http://www.fanden.com.au)

Email: [sales@fanden.com.au](mailto:sales@fanden.com.au)

Introduction.....	3
Specifications.....	4
Principle of Operation.....	5
Simplified Block Diagram.....	5
BITE Diagnostic Display (LEDs).....	5
Operation Flowchart .....	6
Physical Implementation .....	7
Photographs .....	7
Case Dimensions .....	8
Connector Types & Pin Assignments.....	9
Connection Wiring Diagram.....	9
Built In Test Equipment (BITE).....	9
Power In LED.....	9
Error LED .....	9
Power Out LED .....	10
Warning LED.....	10
Remote Bite Port.....	10
Other BITE Information .....	10
Remote BITE port chip characteristics .....	11
Maximum RMS Remote BITE Output Current V's Ambient Temperature .....	11
NiCd Battery Data .....	12
Commissioning & Storage Instructions.....	12
Storage Instructions .....	12
Recommissioning After Storage.....	13
Fault Finding Hints.....	14
Quick Tests Using Built In Test Equipment.....	14
Functional and Battery Test.....	14
Transient Control Test .....	14
Battery Charging Test.....	14
Polarity Protection and Boost Charge Controller Test .....	14
Warning LED & Remote BITE Trip Point Test (workshop test).....	15
General Maintenance & Inspection Procedures .....	15
Schematic Diagram.....	16
Production Equipment & Procedures .....	16

# Introduction

DipFiller for FuelMiser is a device designed to enable the FuelMiser System to remain active during locomotive starting operations when the locomotive battery voltage can “dip” well below the nominal 74 Volts. Dips to 25 Volts are common and locomotives have been known to briefly experience reversed battery polarity during starting (see 81 class locomotive starting trace below).

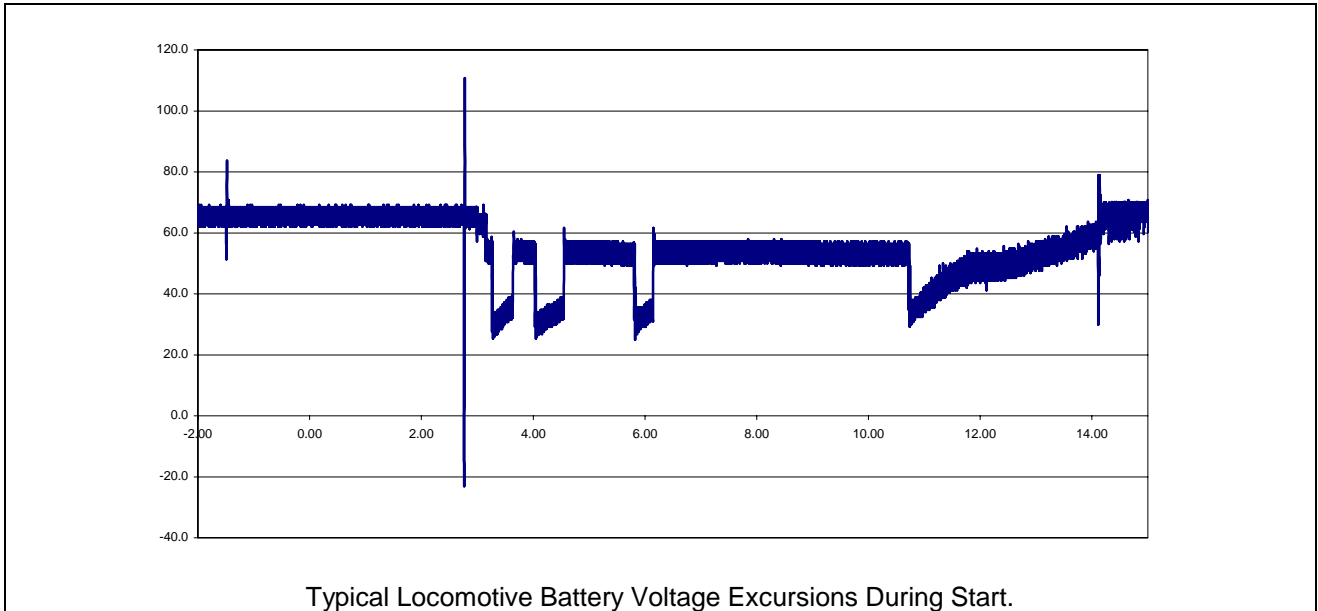

DipFiller addresses these wild locomotive battery voltage fluctuations and ensures the FuelMiser power supply is supplied by a voltage above its specified minimum input of 37 Volts throughout the starting sequence (see DipFiller transfer function below).

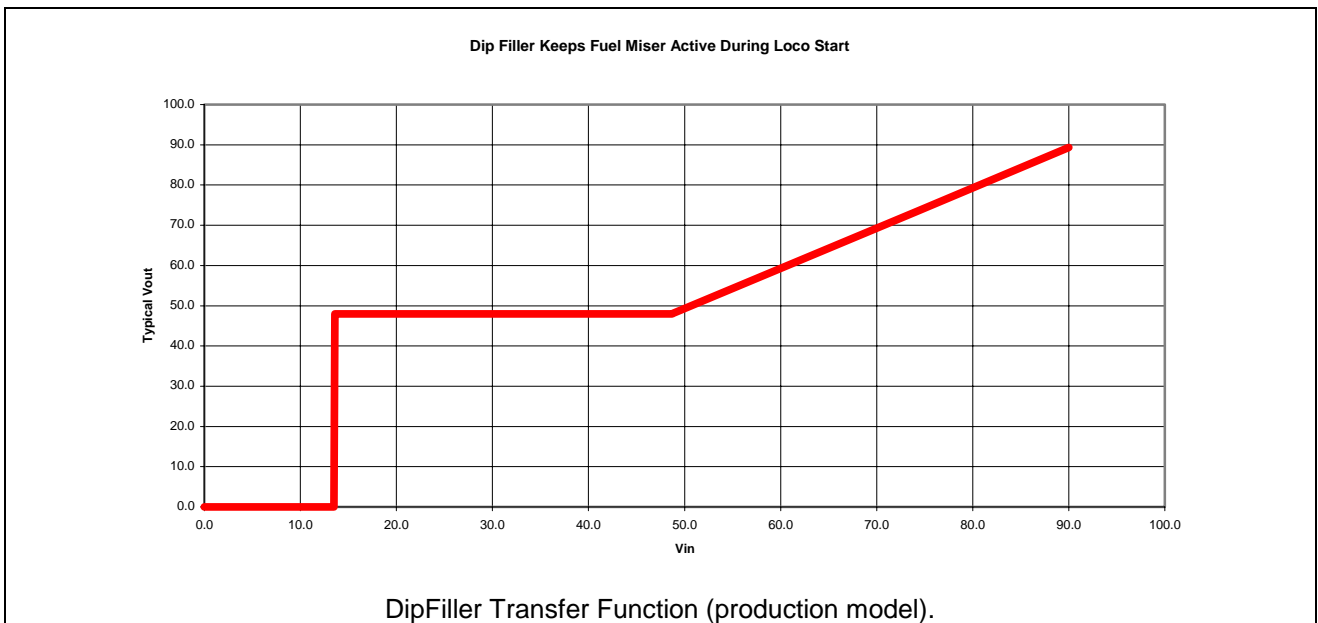

Persons familiar with earlier DipFiller models may notice that the “snap on voltage” has been raised to 15.5 Volts (nom). This was done to eliminate a half second burst of 50MHz energy which could occur if a fully charged DipFiller was switched off whilst connected to a locomotive whose starting battery voltage was between four and five Volts.

## Specifications

	MINIMUM	MAXIMUM	TYPICAL
DC INPUT VOLTAGE RANGE	- 90 V (max boost charge)	+90 V (loco Volt Reg fault)	+74 V (normal loco running)
OUTPUT ACTIVE INPUT VOLTAGE	+15.5 V (snap on Voltage)	+90 V	+74 V (normal loco running)
INPUT CURRENT	0 A	10 A internal HRC ceramic "3AG" fuse	function of load
OUTPUT CURRENT	0 A	10 A internal HRC ceramic "3AG" fuse	function of load
ON DELAY			0.018 SEC
OFF DELAY			0.240 SEC
AMBIENT TEMPERATURE	-10 °C operation -30 °C storage 0 °C boost charge	+ 50 °C operation + 70 °C storage + 45 °C boost charge	
NON-REPETITIVE VOLTAGE SPIKES WHICH THE EQUIPMENT WILL WITHSTAND WITHOUT DAMAGE OR MALFUNCTION	± 7.0 kV for 0.1 µs ± 4.0 kV for 1.0 µs ± 3.0 kV for 3.0 µs ± 0.8 kV for 100 µs ± 0.6 kV for 200 µs ± 200 V for 200 ms		
BOOST CHARGER INPUT VOLTAGE	-90 V	-62 V	-74 V
BOOST CHARGE CURRENT	35 mA nominal at $V_i = -62V$	113 mA nominal at $V_i = -90 V$	68 mA nominal at $V_i = -74 V$
INTERNAL BATTERY VOLTAGE	40 V rec end of discharge NB ≠ output Voltage	62 V approx limit	48 V nominal, 55 V at full charge
OUTPUT WARNING VOLTAGE TRIP POINT		40.1 V	39.8V (approx 1.6 V below internal battery Voltage at $I_o = 10A$ )
REMOTE BITE SWITCH VOLTAGE	on = ± 1.7 V typical (± 3 V max)	± 400 V peak max blocking off state	AC OR DC (NB will latch DC)
REMOTE BITE SWITCH CURRENT	0 mA	± 50 mA at 70 °C (no current protection)	20 mA PLC current loop
FET SWITCH OFF RESISTANCE			> 600 Meg Ohms
NO LOAD INPUT CURRENT			60 mA at $V_{in} = 80 V$
REMOTE BITE SWITCH ISOLATION		1,000 V pk REC MAX 1,750 V pk connector 7,500 V pk opto see note ==>	NB. connecting cable insulation may limit the maximum useable isolation.

# Principle of Operation

## Simplified Block Diagram

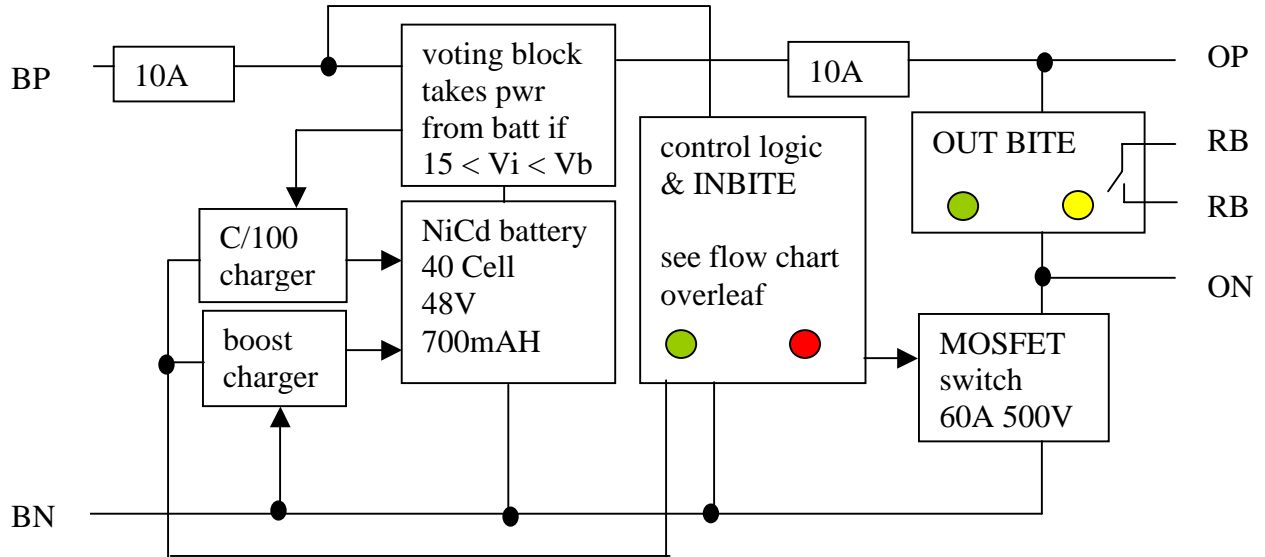

## BITE Diagnostic Display (LEDs)

SITUATION	POWER IN	ERROR	POWER OUT	WARNING & REMOTE BITE	STATUS
BATTERY SWITCH CLOSED NORMAL CONNECTION	ON	OFF	ON AFTER 0.018 SEC DELAY	OFF	NORMAL OPERATION
BATTERY SWITCH OPENED	OFF	OFF	OFF AFTER 0.240 SEC DELAY	OFF	NORMAL TURN OFF SEQUENCE AT LOCO STABLING
BOOST CHARGE <u>NB</u> FREQUENT OR UNNECESSARY USE WILL REDUCE BATTERY LIFE	OFF	ON	OFF	OFF	5 HRS MAX AT 45 °C INCREASING TO 20 HRS MAX BELOW 30 °C
BATTERY WARNING	ON	OFF	ON	ON	LOG FOR SERVICE
INPUT & OUTPUT CONNECTIONS SWAPPED DUE WIRING ERROR	OFF	OFF	ON	OFF	NO POWER TO LOAD NO DAMAGE
INPUT POLARITY REVERSED DUE WIRING ERROR	OFF	ON	OFF	OFF	NO OUTPUT NO DAMAGE
BP TO OUT+ BN TO IN+ DUE WIRING ERROR	OFF	OFF	OFF	OFF	UNLIKELY TO CAUSE DAMAGE
BP TO IN+ BN TO OUT+ DUE WIRING ERROR	OFF	OFF	OFF	OFF	BLOWS FUSE(S) MAY DAMAGE FETs & VOTING BLOCK
OUTPUT SHORT CKT DUE WIRING ERROR	ON	OFF	OFF	OFF	BLOWS FUSE(S) MAY DAMAGE FETs & VOTING BLOCK
INPUT FUSE OPEN	OFF	OFF	OFF	OFF	REPLACE FUSE FIND WHY, RETEST
OUTPUT FUSE OPEN	ON	OFF	OFF	OFF	REPLACE FUSE FIND WHY, RETEST

## Operation Flowchart

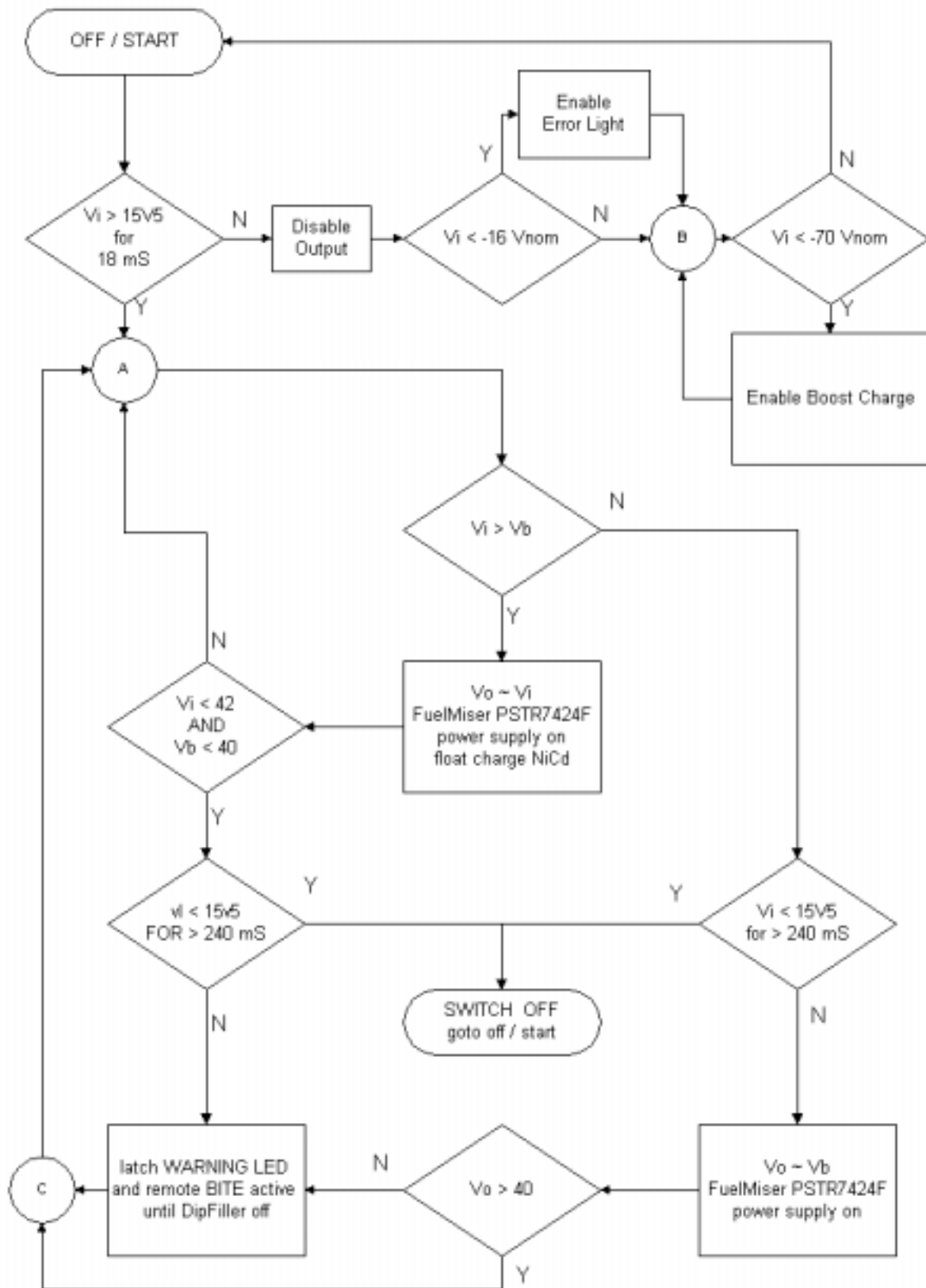

# Physical Implementation

## Photographs

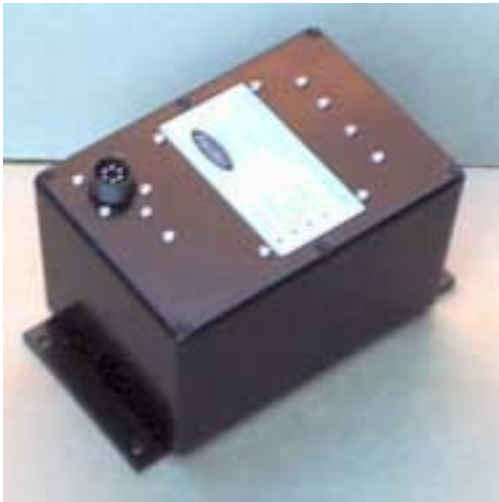

External View



Front Panel Label & BITE Display



NiCd battery with integral shock mounts



Front Panel

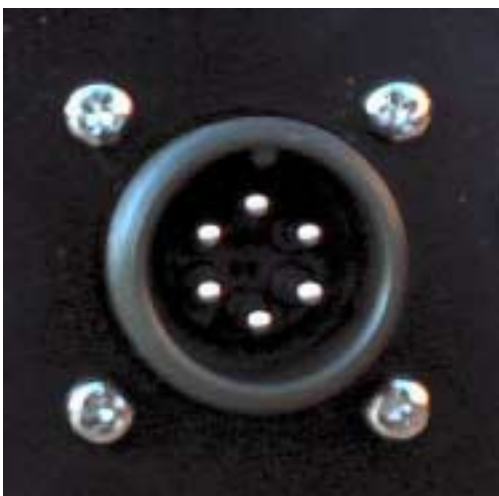

MS3102R14S-6S Panel Connector



HRC Fuses and Panel Connector  
(components both sides of PCB)

# Case Dimensions

## Mounting Base

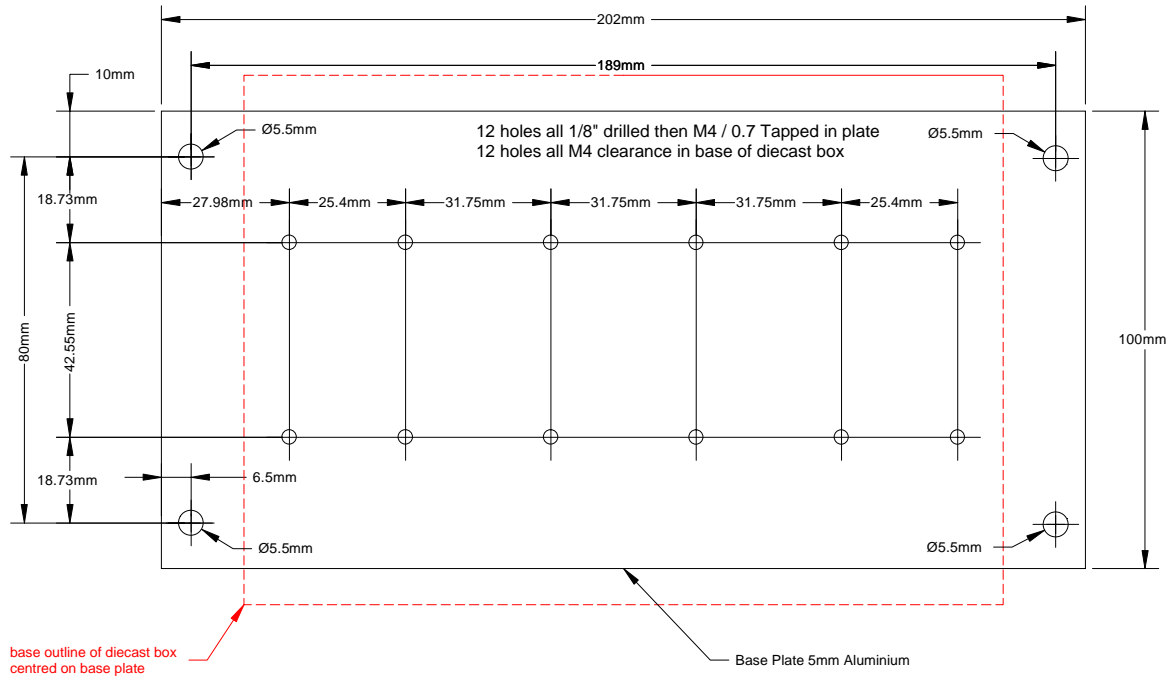

## Bottom View of Top Panel / Lid

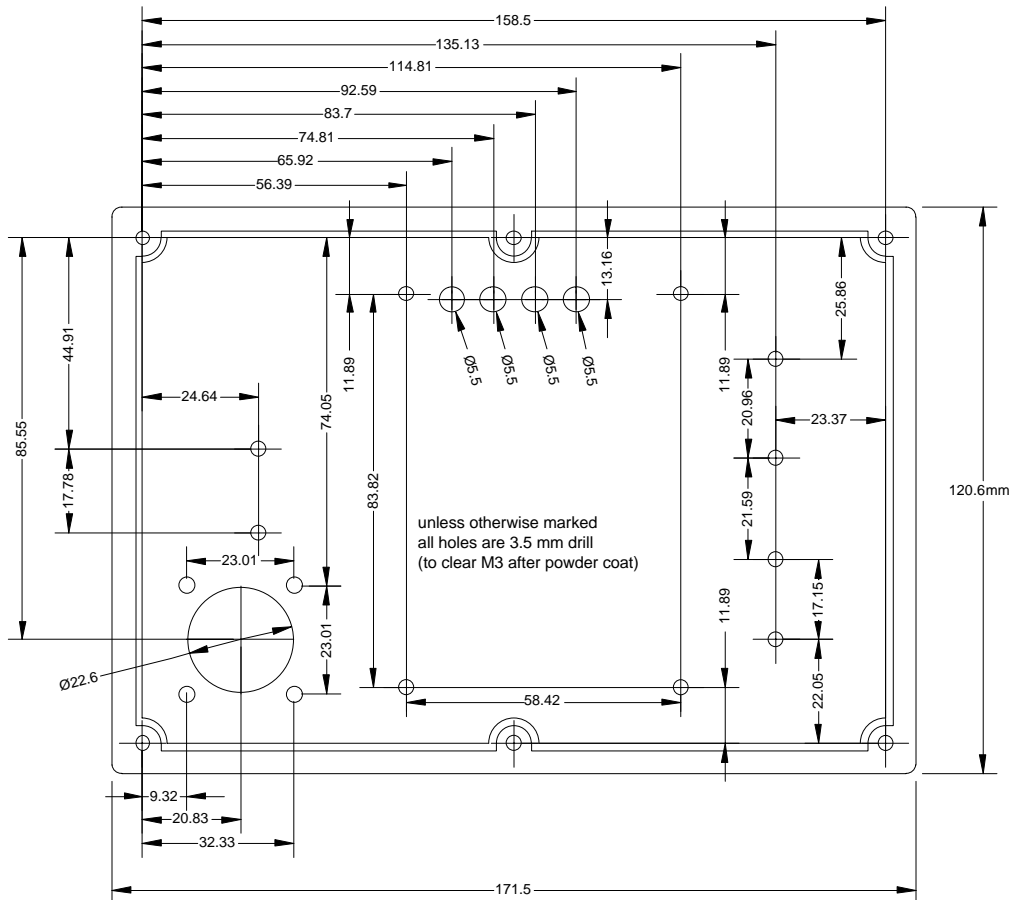

Diecast Box Height = 105.7 mm (Deltron Part No 459-0060)



## Connector Types & Pin Assignments

DipFiller Connector	MS3102R14S-6P	Loco Line “Plug” .....	MS3106F14S-6S
		Loco Connector Rubber Boot	MS3420-6

These are military specification environmental resisting (MSR series) offering a high degree of reliability under adverse conditions.

### Pin Assignments

<b>A</b>	loco BN, do <u>NOT</u> connect to pin B	<b>D</b>	normally open BITE output
<b>B</b>	output negative [ ON or O- ]	<b>E</b>	normally open BITE output
<b>C</b>	output positive [ OP or O+ ]	<b>F</b>	loco BP, do <u>NOT</u> connect to pin C

## Connection Wiring Diagram

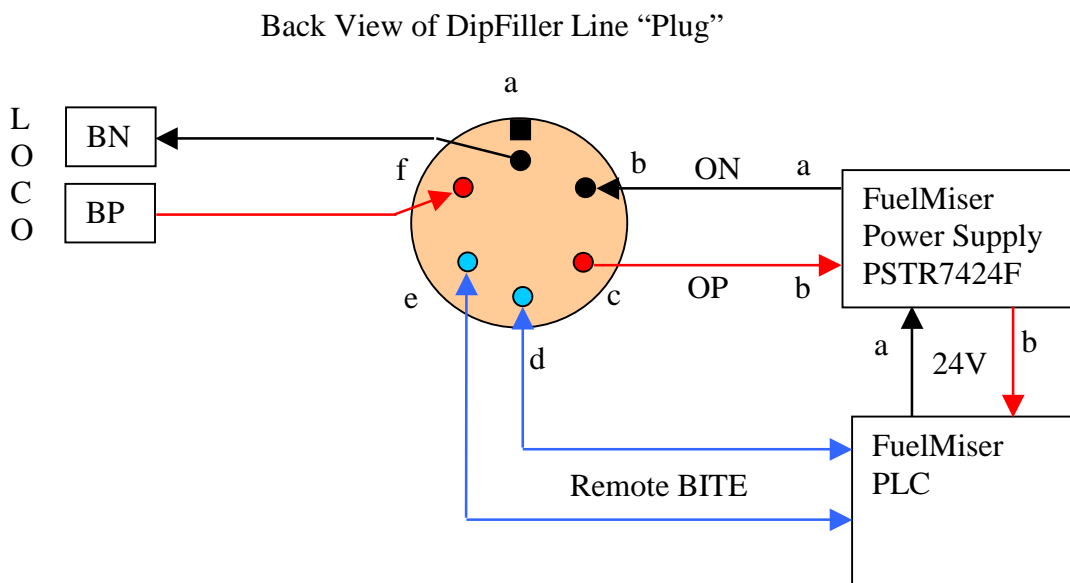

## Built In Test Equipment (BITE)

### Power In LED

An illuminated green “power in” LED shows that the input voltage is present, of the correct polarity and that the 10 Amp input fuse is OK.

### Error LED

An illuminated red “error” LED indicates that the DipFiller input connections have been miswired (reversed polarity). This LED is also illuminated when the DipFiller battery is being boost charged. This LED is for the guidance of technical staff, it should not illuminate in service.

## **Power Out LED**

An illuminated green “Power Out” LED indicates that power is being delivered to the FuelMiser PSTR7424F power supply from which it can be inferred that the input voltage is greater than 15.5 Volts and that the 10 Amp output fuse is OK.

## **Warning LED**

Whilst on, the DipFiller’s output voltage is continuously monitored and a yellow “warning” LED on the top panel is illuminated (and latched on) if the output sags to 40 Volts under peak load. This is three Volts or 7.5% above the minimum specified input voltage for the FuelMiser PSTR7424F power supply and about 5% above the knee in the battery voltage discharge curve. It is thought, but not warranted, that this will give sufficient warning against most battery failures to allow in service failures to be avoided. We cannot warrant this because ageing rates and failure modes are a function of battery treatment which, along with the client’s response to BITE warnings, is outside of our control.

## **Remote Bite Port**

Remote BITE port is an optically coupled normally open silicon bilateral switch which is “closed” whenever the Warning LED is illuminated. This port is isolated to 1,000V and is intended to be used in conjunction with a 20 mA current loop input on the FuelMiser PLC.

## **Other BITE Information**

The *BITE Diagnostic Display (LEDs)* section provides information for train crew and technical staff re interpretation of the BITE LEDs in 12 categories of operation (includes fault modes & wiring errors).

The *Fault Finding Hints* section is a technician’s guide to using the BITE LEDs and altered connections to load test the complete unit, diagnose problems and boost charge “on the road”.

## Remote BITE port chip characteristics

### MAXIMUM RATINGS ( $T_A = 25^\circ\text{C}$ unless otherwise noted)

Rating	Symbol	Value	Unit
--------	--------	-------	------

### INFRARED EMITTING DIODE

Reverse Voltage	$V_R$	3	Volts
Forward Current — Continuous	$I_F$	60	mA
Total Power Dissipation @ $T_A = 25^\circ\text{C}$ Negligible Power in Triac Driver Derate above $25^\circ\text{C}$	$P_D$	100	mW
		1.33	$\text{mW}/^\circ\text{C}$

### OUTPUT DRIVER

Off-State Output Terminal Voltage	$V_{DRM}$	400	Volts
Peak Repetitive Surge Current (PW = 1 ms, 120 pps)	$I_{TSM}$	1	A
Total Power Dissipation @ $T_A = 25^\circ\text{C}$ Derate above $25^\circ\text{C}$	$P_D$	300	mW
		4	$\text{mW}/^\circ\text{C}$

### TOTAL DEVICE

Isolation Surge Voltage <sup>(1)</sup> (Peak ac Voltage, 60 Hz, 1 Second Duration)	$V_{ISO}$	7500	Vac(pk)
Total Power Dissipation @ $T_A = 25^\circ\text{C}$ Derate above $25^\circ\text{C}$	$P_D$	330	mW
		4.4	$\text{mW}/^\circ\text{C}$
Junction Temperature Range	$T_J$	-40 to +100	$^\circ\text{C}$
Ambient Operating Temperature Range	$T_A$	-40 to +85	$^\circ\text{C}$
Storage Temperature Range	$T_{stg}$	-40 to +150	$^\circ\text{C}$
Soldering Temperature (10 s)	$T_L$	260	$^\circ\text{C}$

1. Isolation surge voltage,  $V_{ISO}$ , is an internal device dielectric breakdown rating.  
For this test, Pins 1 and 2 are common, and Pins 4, 5 and 6 are common.

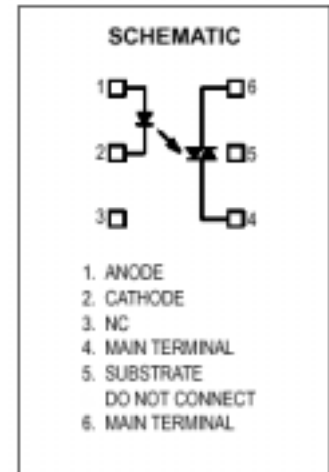

## Maximum RMS Remote BITE Output Current V's Ambient Temperature

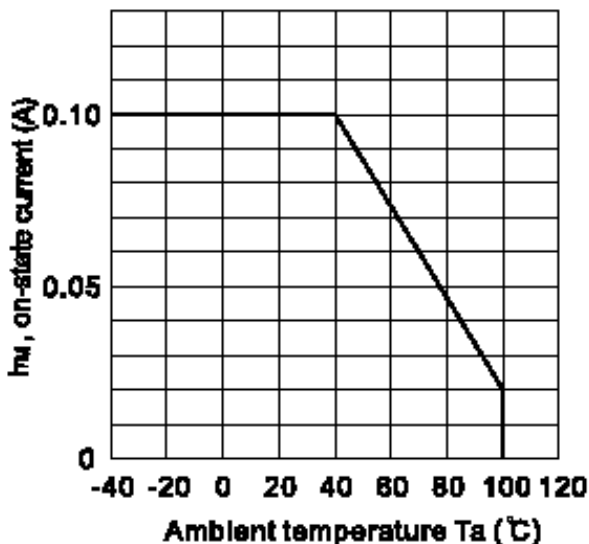

**Please note** that although the opto isolator's specified isolation surge Voltage is 7.5 kV this exceeds both the 1,750V connector specification and typical locomotive low tension cable ratings. With care in cabling a 1 kV isolation surge figure is achievable.

## NiCd Battery Data

### Discharge (at high rate)

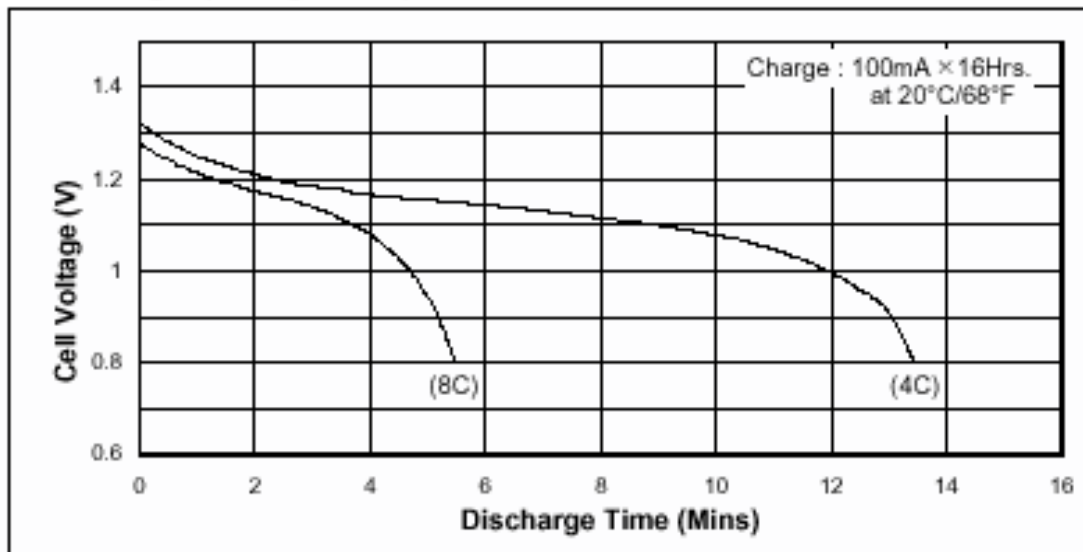

## Commissioning & Storage Instructions

### Storage Instructions

DipFiller may be stored in any orientation with batteries charged or discharged.

Although battery charge state during storage will not impact battery life it will alter the client's ability to rapidly press stored units into service.

The recommended storage temperature limits are  $-10\text{ }^{\circ}\text{C}$  to  $+70\text{ }^{\circ}\text{C}$ . Storage, use or charging above  $70\text{ }^{\circ}\text{C}$  may cause the separator to weaken, the seals to weaken, and greatly accelerate changes in the plate material, some of which cause the dreaded "memory" effect.

Although DipFiller is splash and dust resistant, it is not recommended that this unit be stored unprotected in an area exposed to the weather (rain) or below flood level. It is not waterproof.

## Recommissioning After Storage

DipFiller batteries have minimal deterioration in battery performance even after long term storage. Moreover, the cell capacity decreased by discharging during storage can easily be restored to its original level by recharging.

That said however, all batteries, including NiCd batteries, will self discharge in storage. Although they are better than NiMH & lead acid cells in this respect NiCd cells can lose around 25% of capacity per month of storage with self discharge accelerating as temperature increases (see graph below).

Although much longer periods are possible, we recommend that cells stored for more than 6 weeks should be allowed to charge from the locomotive batteries or other suitable supply before being placed into service.

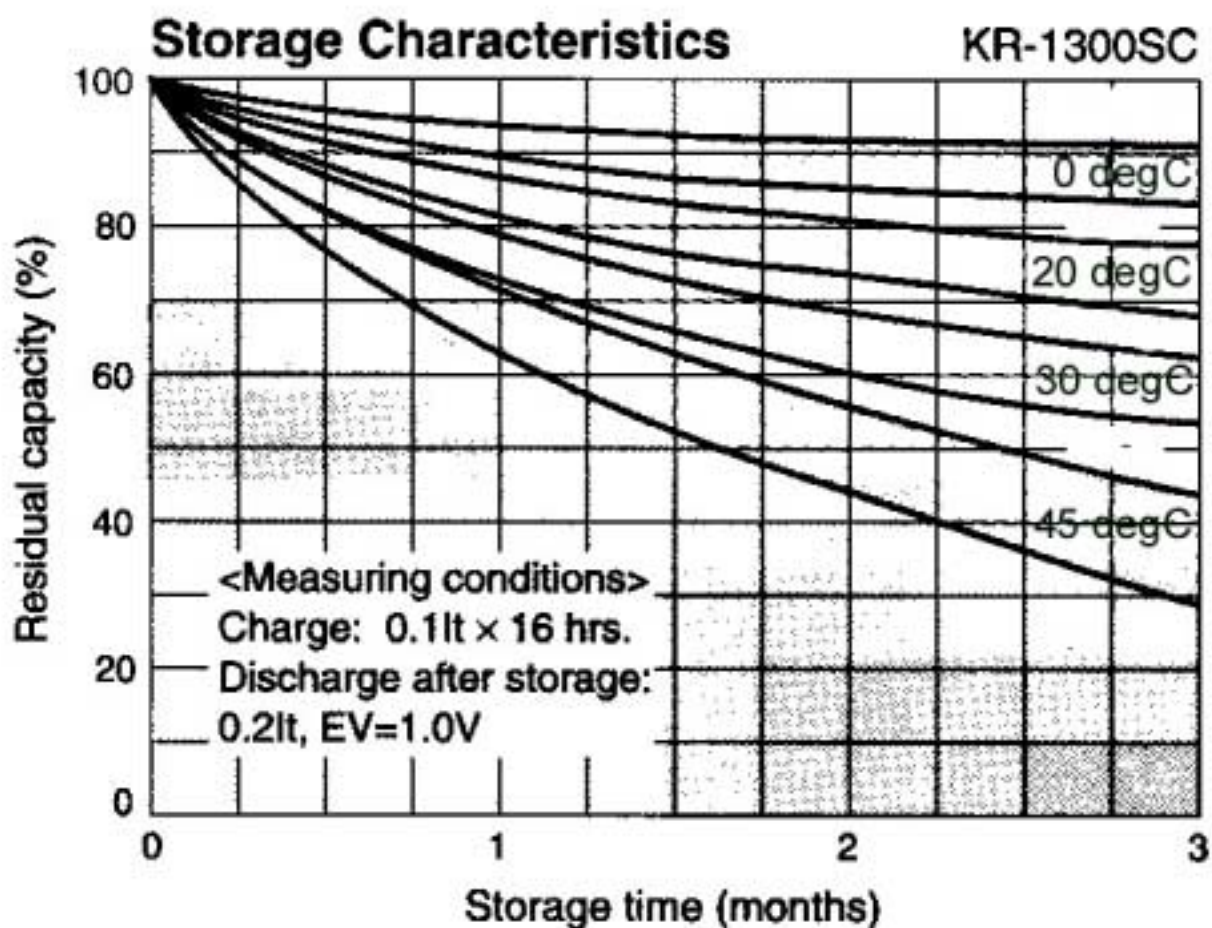

## Fault Finding Hints

### ***Quick Tests Using Built In Test Equipment***

#### **Functional and Battery Test**

- ❑ Disconnect pin (F) [loco battery positive] from locomotive wiring and carefully bridge pins (C) and (F) for a few seconds.
- ❑ Input LED will light to show both input & output fuses are OK,
- ❑ Output LED will light to show the battery has more than 15.5 Volts of charge.
- ❑ If the warning light does not light this shows that the battery is OK (has more than 40 Volts of charge). With suitable care (or a test box) this test may be conducted with the PSTR7424F power supply & FuelMiser equipment still connected which allows full load test of the unit. Such full load testing from the internal battery should be restricted to no more than 5 seconds duration as it will discharge even a fully charged battery within about 4 minutes.
- ❑ NB. *Although this procedure allows a full function test to be performed 'on the road' using nothing more sophisticated than a piece of wire we do NOT recommend this process be explained to non technical staff who may inadvertently fully discharge the NiCd battery or worse.*

#### **Transient Control Test**

- ❑ An observant person may observe a short delay between the input and output LEDs. There is a short delay switching on and a slightly longer delay switching off. This delay is to assist in isolating the load from short transients in and reversals of the locomotive's auxiliary supply.

#### **Battery Charging Test**

- ❑ Disconnect pins (C) and (B) from locomotive wiring and reconnect pin (F) to locomotive battery positive via an ammeter. Current draw should be near 60 mA with input & output green LEDs only illuminated. (note: this is mostly LED and battery charge current it will vary with battery charge state and locomotive starting battery voltage)

#### **Polarity Protection and Boost Charge Controller Test**

- ❑ Disconnect pins (F) and (A) and reconnect them with reverse polarity [(A) to positive and (F) to negative] via an ammeter. Current draw should be near 90 mA with only the red error LED illuminated. Steady state output voltage [pin (C) to pin (B)] = zero Volts. Note that when this test is performed rapidly (by Automatic Test Equipment) the output voltage will not drop to zero immediately on input polarity reversal due the delayed off feature which prevents short term loss or reversals of input voltage being reflected in the output voltage.

## Warning LED & Remote BITE Trip Point Test (workshop test)

- ❑ connect the negative output terminal of a variable voltage regulated supply to Output Negative (pin B)
- ❑ set the variable supply Voltage anywhere between 50 and 90 Volts BEFORE
- ❑ connecting the positive terminal of a variable voltage regulated supply to Output Positive (pin C).
- ❑ the Power Out LED will light and the Power In, Warning and Error LEDs will be off, confirming your connections
- ❑ connect an ohm meter or DMM set to diode test position to the remote BITE port (pins E and D). Polarity is unimportant. This should indicate open circuit. Note this is a low current port, do NOT use a bell set or lamp box to test this port).
- ❑ SLOWLY reduce the variable supply voltage until the Warning LED snaps on and check that this voltage is sensibly close to 40 Volts (it is easy to overshoot and miss this point, take care).
- ❑ Note that DipFiller uses a laboratory grade voltage reference to set and hold the trip point to an accuracy better than many DMMs. It is extremely unlikely to drift out of range and is not adjustable hence accurate measurement is not required, this is purely a functional test.

## General Maintenance & Inspection Procedures

- ❑ Check that the green “Power Out” LED IS illuminated and the yellow “Warning” LED is NOT illuminated after the locomotive is started.

Please note that, if tripped, the yellow “Warning” LED will remain latched on until locomotive battery supply is removed. This allows the LED state to be checked by maintenance staff or train crew at any time after starting and before stabling the locomotive.

If the warning LED is telemetered to the Driver’s FuelMiser console as intended, any problems here will normally be reported by Train Crew before they are noticed by maintenance staff.

A yellow “Warning” LED indicates looming or immediate battery problems, either because of over discharge<sup>1</sup>, dendritic growth between the plates shorting cells or other cause. Although faulty batteries need to be replaced ASAP, it is wise to check the battery’s recent history before making a possibly unnecessary replacement, it may only need a charge.

- ❑ If there is an excessive build up of coal dust or similar then this may be removed using a dry or damp cloth to lightly wipe the top panel (lid) clean. Solvents and detergents are not required nor should the cloth be wet. Do not pressure wash or hose the unit. Only client can determine the cleaning schedule (if any). We would be surprised if cleaning is required more than once per year.  
NOTE: It does not need to be spotlessly clean, this is done to improve LED visibility and increase cooling efficiency (battery life is a function of temperature).

---

<sup>1</sup> do not forget self discharge can ‘flatten’ the battery if the locomotive or DipFiller has been out of service for some time.

# Schematic Diagram

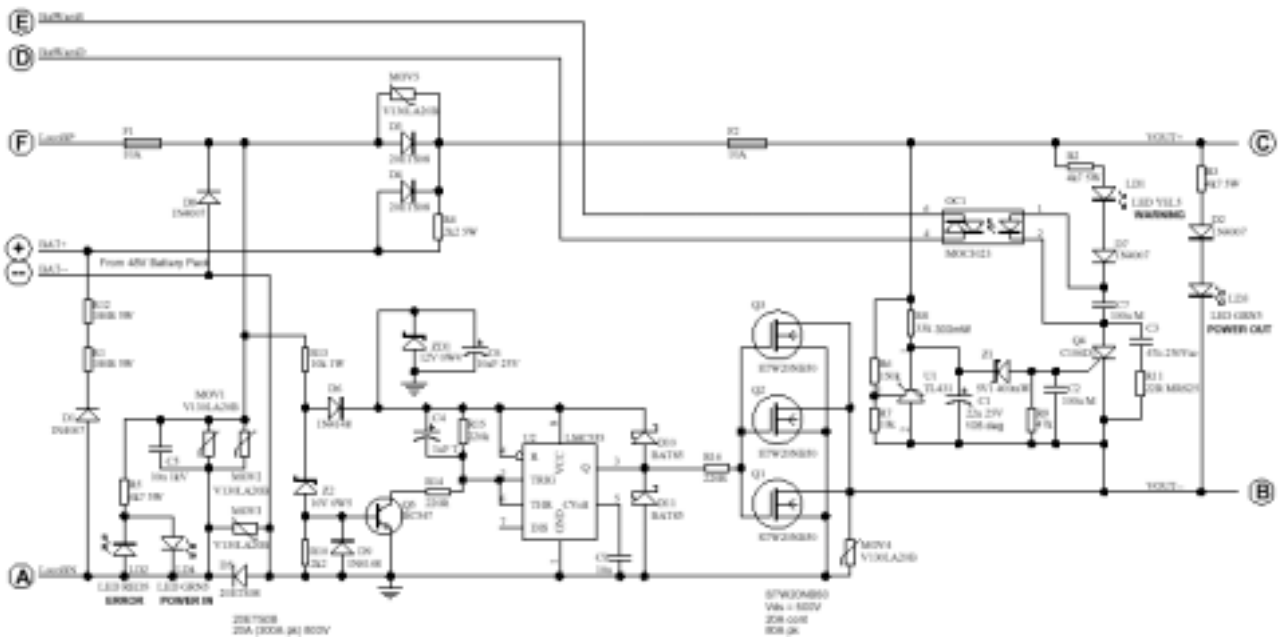

# Production Equipment & Procedures

(eg off and on loco boost charging, automated battery capacity test set, ATE, etc)

Intentionally left blank in client editions.